



Ultra Motion Power Supply Unit User Manual

DC Power Supply Unit for Motion Control Applications

Model No's: PS-1X0 and PS-1X2



Safety Information

IMPORTANT: Read this manual before installing and operating the Ultra Motion Power Supply. Failure to read this section can result in personal harm or damage to the product.

Safety Disclaimer

This power supply is intended to be a subcomponent of a larger piece of machinery or automated system. This section is not intended to provide the safety guidelines for the entire machine or system that the power supply is installed into. It is the responsibility of the purchaser or system designer to assess the risks and safety requirements of the end application they are designing.

If the power supply is to be used in a safety critical application, the purchaser or system designer must perform appropriate safety testing to ensure that the product meets the requirements and safety criteria for their application.

Ultra Motion has made all reasonable efforts to present accurate information in this document and is not responsible unintentional oversights. If, at any time, the purchaser has questions or uncertainty about information in this manual, contact Ultra Motion to speak with an engineer.

Safety Warnings

- As this power supply is unregulated, it is capable of outputting power far in excess of its maximum continuous load rating. Please ensure that your supply and fuses are appropriately selected for the application, and temperature is appropriately monitored in order to protect the PSU and the attached system. See the Power Output Capacity on page 6 for more information.
- Even after removing AC power, the supply still retains a considerable amount of energy in large internal capacitors. This will cause the supply to continue to output DC voltage until drained (the energy will drain naturally over a few minutes). Throwing the main power switch or removing AC power should never be used to rapidly de-energize the system, especially in emergency situations. Please use an Emergency Power Off (EPO) switch per our guidelines (on page 5) to safely accommodate safe and rapid removal of power.
- The main terminals of the PSU are not insulated, and must be protected from accidental short circuit or anything else that may be damaged by a 36VDC differential.
- At high current draws, case of the PSU can become very hot. Take adequate time to cool before handling.
- Provide adequate ventilation for cooling of this device.

Safety Notifications



As you read through the manual, you will notice certain safety notifications that indicate other important safety related information.

Table of Contents

Safety Information	2
Introduction	3
Product Features	4
Available Models	4
Layout	4
Operating with Emergency Power-Off (EPO) switch	5
Quick Start Guide	5
Common Issues & Troubleshooting	5
Operating Information & Performance	6
Power Output Capacity	6
Load Regulation	7
Efficiency	7
Dimensions	8
Mounting Options	8
Integrated Over-Voltage Protection (OVP) device	10
Theory of Operation	10
OVP Application Example: Rapid Deceleration under Load	10
Contact Information	11

Introduction

The Ultra Motion Power Supply Unit is an unregulated AC to DC supply designed specifically for DC motion control applications, including [ServoCylinder](#), and is perfectly suited to most 36V DC motor applications. A Power Supply Unit (PSU) used in DC motion control applications must be sufficiently robust to provide the large bursts of current typical of motor acceleration, while also being capable of tolerating large voltage spikes generated by the motor during deceleration.

In DC motor applications, unregulated DC power supplies tend to greatly outperform the more common switching-type regulated supplies. Unregulated supplies have large capacitors which allow for large transient current draws and help to absorb voltage spikes. Furthermore, they are not subject to the large overshoots and undershoots characteristic of a voltage controller, which have a detrimental impact on motor performance, and potentially destructive impact on motor controller hardware, motor windings, and other equipment attached to the same power bus.

The Ultra Motion PSU utilizes a high-efficiency toroidal AC transformer, high performance rectifiers, and a large aluminum electrolytic capacitor. It also has a fully enclosed extruded aluminum housing which provides dust protection while also allowing adequate cooling. Furthermore, it has a fully integrated Over-Voltage Protection (OVP) device (similar to the Ultra Motion Power Shunt) which protects the bus from excessive voltage spikes due to both deceleration and Loss of Power (LoP) scenarios.

Product Features

- Type: Unregulated AC to DC Power Supply
- Input: 100-125VAC, 50-60Hz
- Output:
 - 36VDC Unloaded, TYP
 - 30VDC Maximum Continuous Load, TYP
- Fully integrated Over-Voltage Protection (OVP) device
- Emergency Power Off (EPO) ready
- High efficiency (over 80% at 10-100% of max continuous load), Quiescent power <5 watts.
- Regenerative, recaptures energy generated by deceleration
- 100% RoHS Compliant
- Dust-Resistant (IP50)
- Fused AC Input (5mm x 20mm Fuse, 250V, slow-blow, 6.3A)
- Fused DC Output (1/4" x 1-1/4" Fuse, 250V, slow-blow, application-dependent current rating)
- Temperature ranges:
 - Operating: -10°C to +65°C (+14°F to 150°F)
 - Storage (Non-operating): -55°C to +85°C (+67°F to 185°F)

Available Models

Model	Part Number	Maximum Continuous Load (@72°F)	Well Suited for...
Ultra Motion 180W PSU	PS-1X0A	5.92A (About 180W)	1x ServoCylinder (Typical Applications)
Ultra Motion 360W PSU	PS-1X2A	11.75A (About 360W)	1x ServoCylinder (Hi-Power Applications), or 2x ServoCylinders (Typical Applications)

Table 1: Power ratings of all available PSU Models

Layout



- | | | |
|---------------------------|---------------------------------|---|
| 1. Power Switch (Lighted) | 2. Line-in Connector (C13 line) | 3. AC Fuse Holder |
| 4. DC Fuse Holder | 5. Power Output Indicator Light | 6. Over-Voltage Protection (OVP) Active |
| 7. EPO Out | 8. EPO In | 9. Positive (Red) |
| 10. Negative (Black) | 11. Ground (Earth/Chassis) | 12. Rail for #10 Square Nut |

Figure 1: Layout of Ultra Motion Power Supply. All screw terminals are #6

Operating with Emergency Power-Off (EPO) switch

The Ultra Motion PSU has been designed with special considerations for compatibility with an Emergency Power-Off (EPO) switch, also known as Emergency Stop, E-switch, EMS, or EMO. Since unregulated PSUs have capacitors that can retain energy for some time after removal of AC power, an effective EPO switch must interrupt the DC output of the supply. However, if the switch interrupts the circuit between the motor and the PSU, the integrated OVP device will be rendered inoperable.

The Ultra Motion PSU has pair of external terminals (EPO In and EPO Out) which are shipped with a jumper installed. To use an EPO, simply remove the jumper installed by default and install a switching device or relay between these terminals. Breaking the continuity between EPO In and EPO Out will immediately remove power without removing the OVP device from the circuit.

The EPO switching device and its leads will carry the full output current of the PSU, and therefore a suitable device must fulfill the following minimum requirements:

- Current rating: Exceeds DC fuse rating (20A suggested)
- Voltage rating: 36VDC Minimum
- Leads: 12AWG or heavier wire, with appropriate length (≤ 10 ft suggested)
- Recommended: Normally Closed (NC) Push-lock "Emergency Stop" switch



Figure 2: EPO terminals with jumper installed

Quick Start Guide

1. Begin with an unwired PSU
2. Ensure that both (2x) fuses are installed. The DC fuse should be appropriately selected to protect the equipment and the PSU. A 20A fuse is typically shipped by default.
3. *If not using an EPO device*, leave provided jumper connecting "EPO Out" and "EPO In" installed.
4. *If using an Emergency Power Off (EPO) switch*, remove EPO jumper and wire both terminals of the EPO switch into the "EPO Out" and "EPO In" terminals.
5. Connect the Positive (+), Negative (-), and Ground (if available) terminals.
6. Connect the Line-In AC cable (100-125VAC, 50-60Hz)
7.  Activate PSU with Power Switch. Ensure red "OVP" LED remains nominally off with system active. **Deactivate immediately if this happens.**
8. During operation, ensure surface temperatures remain below 150°F (65.5°C)

Common Issues & Troubleshooting

- Symptom: No output voltage, Power Switch is lit, green PWR light is off
 - Likely Causes:
 - (If operating with EPO switch) EPO switch is open
 - (If operating without EPO switch) EPO Jumper not installed
 - DC fuse is blown
- Symptom: No output voltage, Power Switch light off, other LEDs off
 - Likely Causes:
 - AC fuse is blown
 - No Line-in voltage
- Symptom: OVP light on when starting PSU (**Deactivate immediately if this happens**)
 - Likely Causes:
 - Excessive Line-in AC voltage

Operating Information & Performance

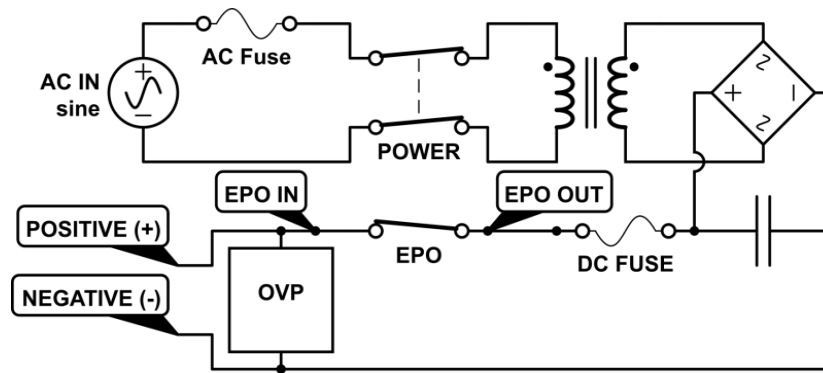

Figure 3: General Schematic of PSU. Some models may vary slightly.

Power Output Capacity

The limiting factor controlling the maximum continuous output power is the temperature rating of the transformer windings, which are NEMA Class B. We generally recommend preventing the top surface temperature of the PSU from exceeding 150°F (65.5°C). Under ordinary conditions (ambient temperature ~72°F, placement on non-conductive wooden surface, minimal forced convection) we find that this usually corresponds to transformer core temperature of about 250°F (121°C).

The supply is designed to allow short duty-cycle bursts of power, so the transformer has a very large thermal mass and will take several hours at maximum continuous power output to reach maximum steady state temperature. Figure 4 below depicts temperatures of various PSU components when subjected to the max continuous load and ordinary conditions.

It is possible to improve the life of the PSU and/or allow for larger sustained loads by improving the cooling conditions beyond what we define as ordinary conditions. You can heat sink the base of the PSU to draw heat, or improve air flow in order to aid heat convection.

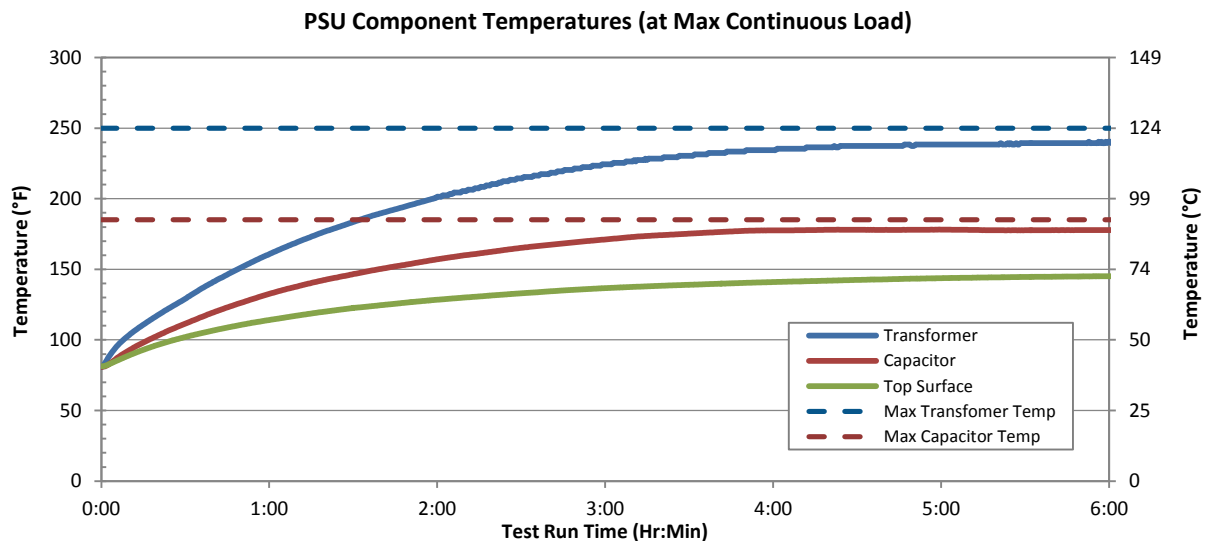

Figure 4: Temperatures of various components as they approach steady state while the PSU is subjected to the maximum rated continuous load. The dashed numbers represent the maximum safe temperatures of each component.

Load Regulation

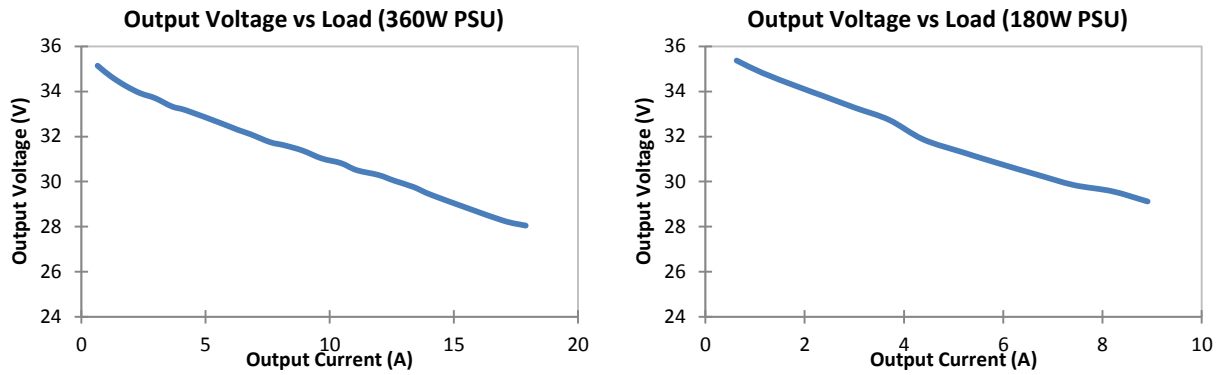

Figure 5 & 6: Load Regulations of PS-1X0 PSU and PS-1X2 PSU respectively, based on 122V_{rms} Line-in.

Efficiency

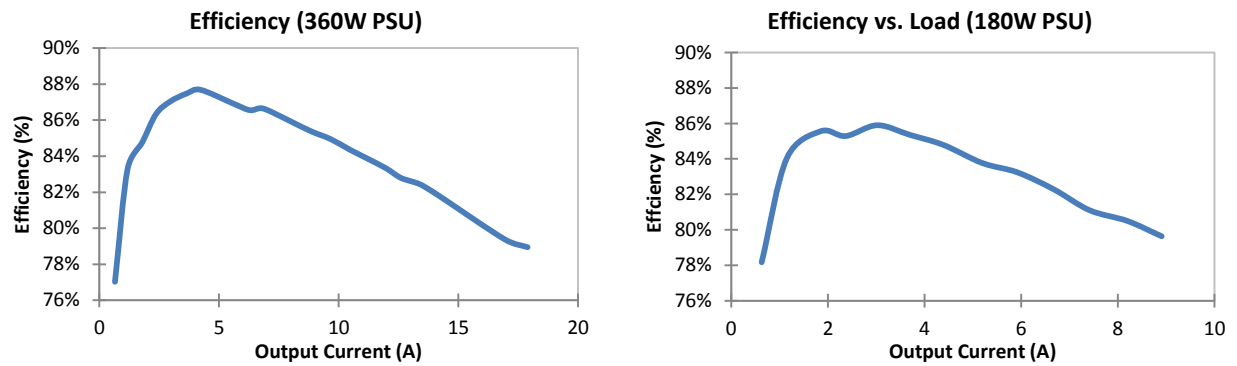

Figure 7 & 8: Efficiency of PS-1X2 PSU and PS-1X0 respectively, based on 122V_{rms} Line-in

Dimensions

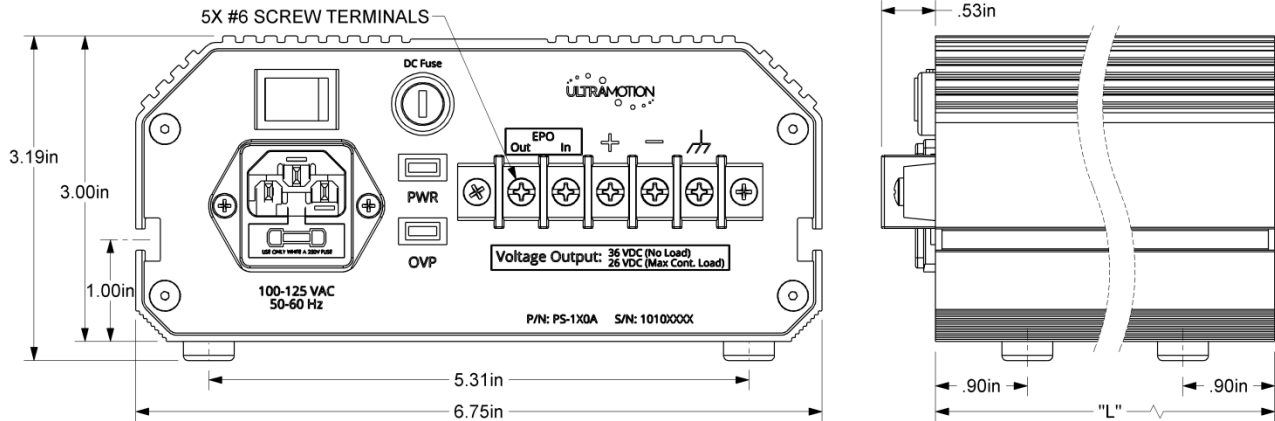

Figure 9: Outside geometry. CAD Models available upon request.

Model	Part Number	Case Length ("L")	Bottom Hole Spacing ("S")
Ultra Motion 180W PSU	PS-1X0A	10in	8.195in
Ultra Motion 360W PSU	PS-1X2A	12in	10.195in

Table 2: Geometry of all PSU models

Mounting Options

The Ultra Motion PSU is fitted with four (4) rubber feet is ready to use out of box when set on any horizontal flat surface (Option A). In the event that PSU must be secured or mounted, it is designed to be configurable with several additional mounting options. The case is not sensitive to orientation and may be mounted at any angle.



Ensure the placement or mounting surface will not be damaged by the high case temperatures.

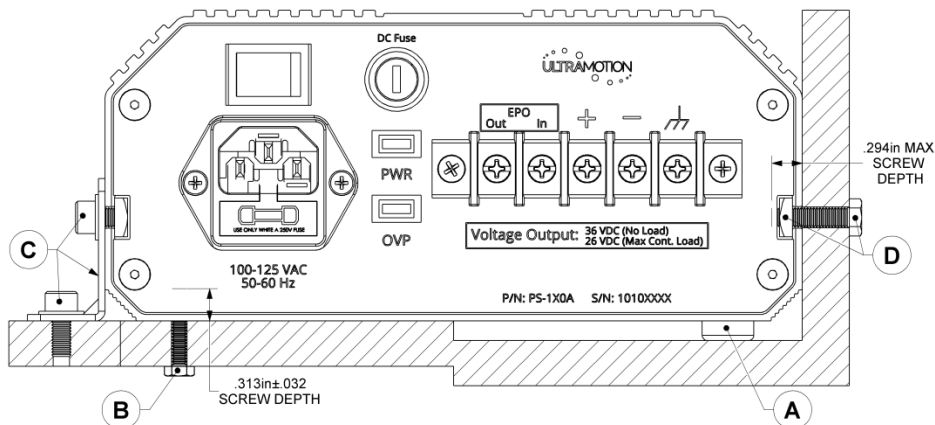

Figure 10: Diagram depicting all primary mounting options.

(A) Surface placement with rubber feet, (B) Bottom Mount, (C) Bracket mount, and (D) Side Mount

Option A: Surface Placement

The power supply ships with 4x rubber feet perfect for placement on most horizontal surfaces with minimal vibration.

Option B: Bottom Mount

After removing rubber feet, 4x #6-32 UNC blind nuts become available. Take care to install screws to a depth *not exceeding* .345in from bottom surface.

Recommended: 4x Screws

Option C: Bracket Mount (With optional PSU Mounting Bracket)

Useful if opposite panel side is inaccessible, the PSU Mounting Bracket (P/N: 15399) has an adjustable position, and a .02in (#10) x .38in mounting slot.

Recommended: 4x Brackets

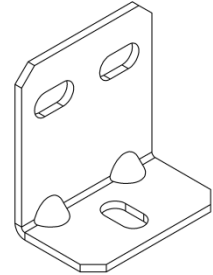

Figure 11: PSU Mounting Bracket P/N 15399

Option D: Side Mount

The side of the case features a #10 T-rail, which accepts a standard #10 square nut and allows screw installation to a maximum depth of .294 from the side surface.

Recommended: 2x Screws Minimum

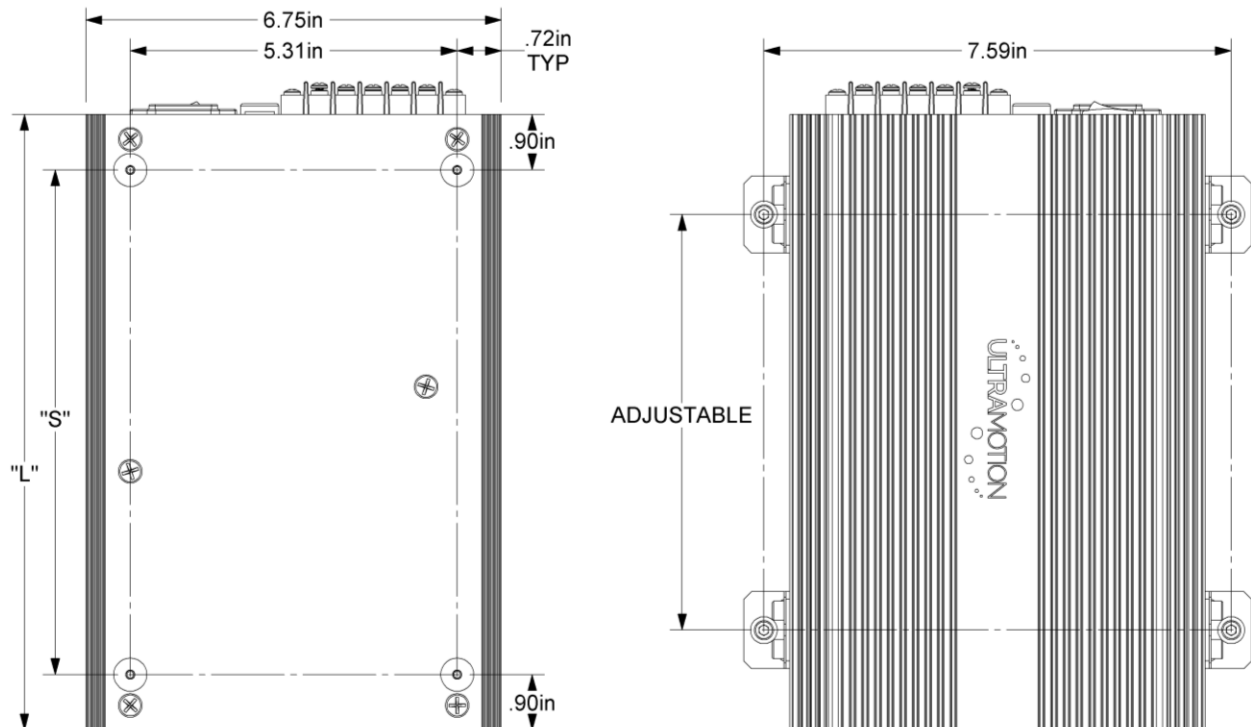

Figure 12: Hole patterns for Bottom-Mount (Left) and Bracket-Mount (Right). See Table 2 for values for "S".

Integrated Over-Voltage Protection (OVP) device

The PSU contains the same proven technology used in our standalone OVP device, the Ultra Motion Power Shunt. It is specifically designed to safely dissipate any potentially damaging voltage spikes generated by the system, such those that can occur when motors are rapidly decelerating, or from release of energy in Loss of Power (LoP) scenarios.

The system senses bus voltage, activating when the voltage exceeds a pre-programmed value of 41.6V. It then drains excessive voltage to ground over a high-power shunt resistor until bus voltage is reduced to 37.5V before deactivating.

Theory of Operation

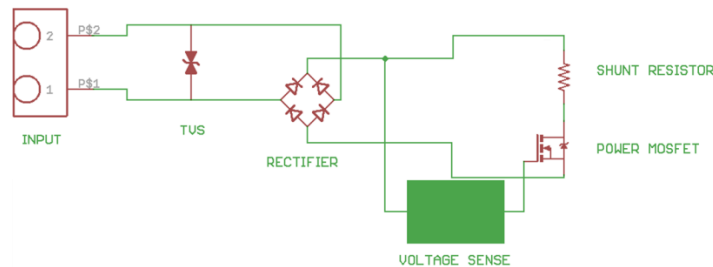

Component	Purpose
TVS	Suppresses ESD, lightning, and other high-speed, high-voltage transients
Rectifier	Render the OVP device bipolar. The shunt will activate when $ V_{in} > V_{act}$
Voltage Sense	Continuously compares the bus voltage with a pre-configured V_{act} voltage. When $ V_{in} > V_{act}$, this circuit will switch the POWER MOSFET. The circuit features a hysteresis band of $\sim 4V$.
Power MOSFET	Once activated, allows the system to rapidly drain power from the main bus through the Shunt Resistor. The MOSFET has been sized to support a maximum continuous current of 72A.
Shunt Resistor	Dissipates the undesired bus energy into heat. Resistor is designed for high pulse energy to allow dissipation of a large amount of energy in a single burst.

Figure 13 & Table 3: Schematic of OVP system (Top) and OVP system components and descriptions (Bottom)

OVP Application Example: Rapid Deceleration under Load



Figure 14: In this application, an Ultra Motion ServoCylinder with a BLDC Motor is rapidly decelerating an 80 lbm mass. The bus voltage (yellow) rapidly rises at the beginning of the period of rapid deceleration until it hits $V_{act} = 29V$ and then quickly drops when the shunt is activated. The shunt activation periods are indicated by high MOSFET voltage (green). The OVP device in the Ultra Motion PSU triggers at 41.6V, and deactivates at 37.5V.

Contact Information

If you have any questions about the Ultra Motion PSU or any of our other products, contact us by leaving a web inquiry (to be replied to within one business day) at: ultramotion.com/contact

Alternatively, you may reach us by using one of the following options:



LIVE CHAT

Live Chat directly with one of our engineers:

ultramotion.com



EMAIL

Email will be replied to within one business day:

info@ultramotion.com



CALL

PH: 888-321-9178

Fax: 631-298-6593



ADDRESS

Ultra Motion

22355 CR 48, #21

Cutchogue, NY 11935



HOURS

Our Business Hours:

Monday-Friday

9AM – 5PM EST

